

Technical Specifications

Power Options

- Mains
- Battery
- Solar

Motor

- Tilt & Lift 12v RTS

Materials

- Aluminium Hardware
- Honeycomb Fabric

Finishes

- White
- Anthracite
- Black
- ⊗ Bespoke

Fitting Options

- Recess Mount

Frame Options

- L-Profile Side Trims

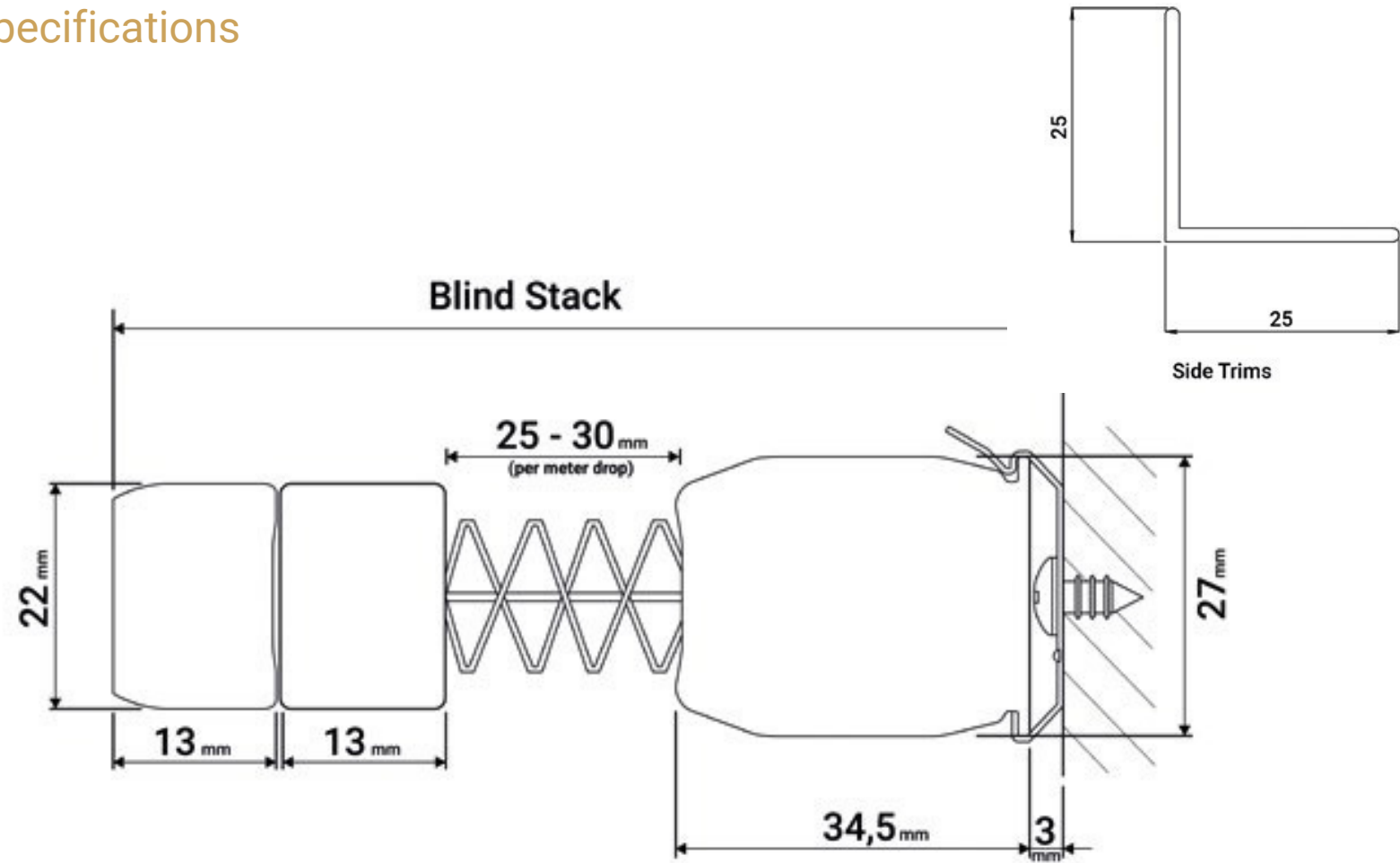
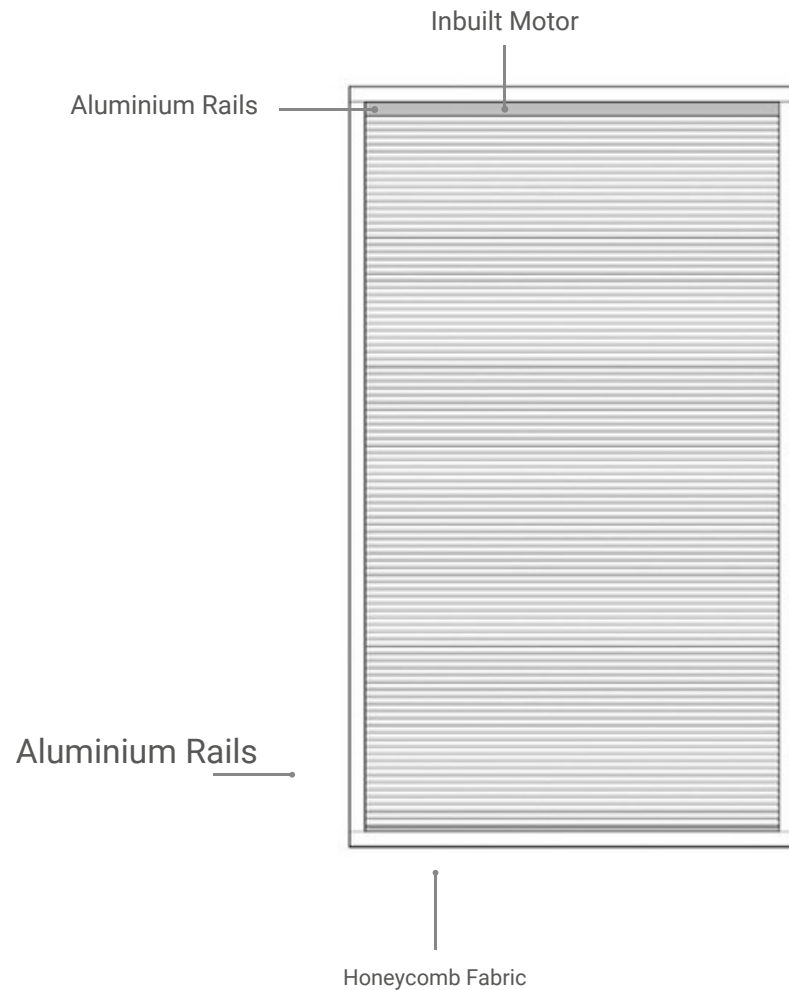



s through
ords are
system.

Cord Guide

KEY

Spooling cord – this white cord travels through the central section of the fabric. Cords are paired together as an 'extend & return' system. Cord pairs are spaced 20mm apart. Spooling cords are visible when the blind fabric is compressed closed. Support nylon – this semi-transparent nylon cord is fitted to provide fabric support. Nylon cords are visible when the blind fabric is compressed closed.

350MM - 699MM WIDE



700MM - 1100MM WIDE

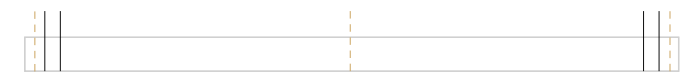

1101MM - 1400MM WIDE



1401MM - 2200MM WIDE



2201MM - 3000MM WIDE

