

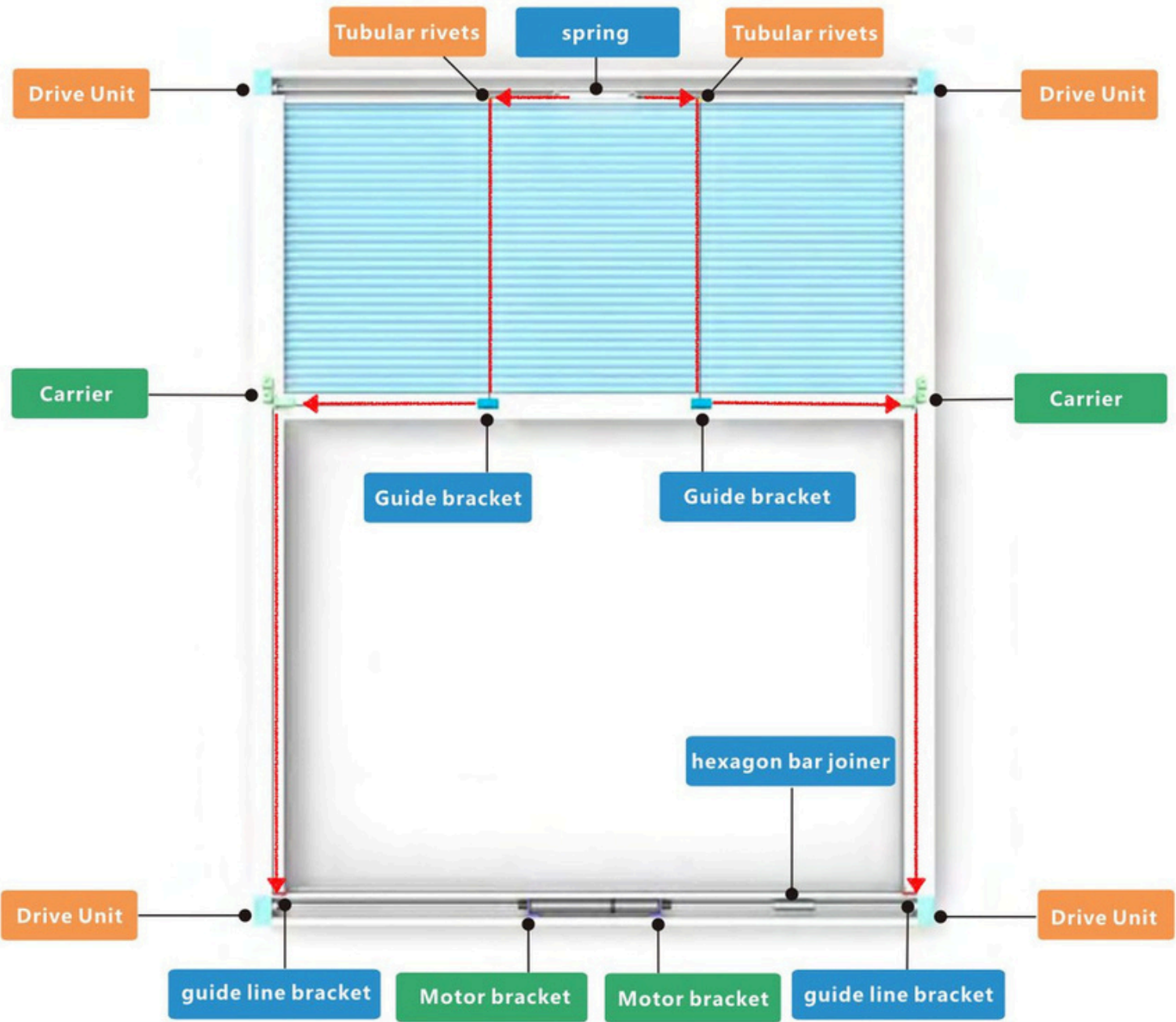

Honeycomb Openview (Electric blind assembly guide)

Anatomy Of The Blind

Head Of Blind (where battery or transformer is hidden)



Foot Of Blind

How To Assemble The Blind

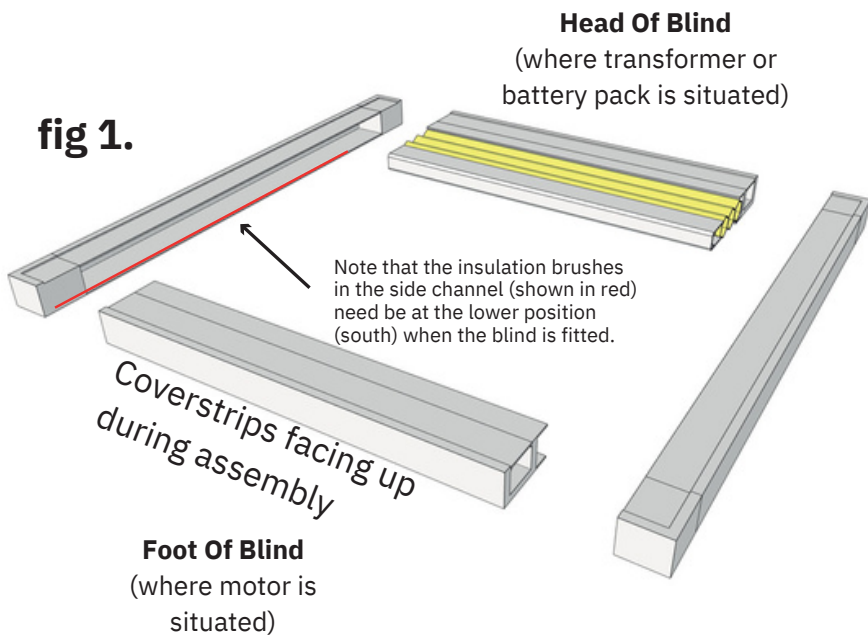

[Scan for assembly instructions or click here](#)

Carefully unpack the blind and arrange the blind on the floor as shown in **fig 1**.

Next, watch this video to see how to assemble the blind before installation.

THE BLIND HAS NUMBERED LABELED STUCK ON TO IT. PLEASE MATCH UP EACH NUMBER TO THE MATCHING NUMBER EG 1-1, 2-2, 3-3 etc.

IF THIS ISN'T DONE THE BLIND WON'T WORK



Test the blind on the floor before you fit it into your recess.

Joining The Side Channels

If your blind is over 2.9m long the side channels will come in 2 pieces (for ease of transit). Follow this video to join the side channels. If your blind is smaller than 2.9m move to the next step

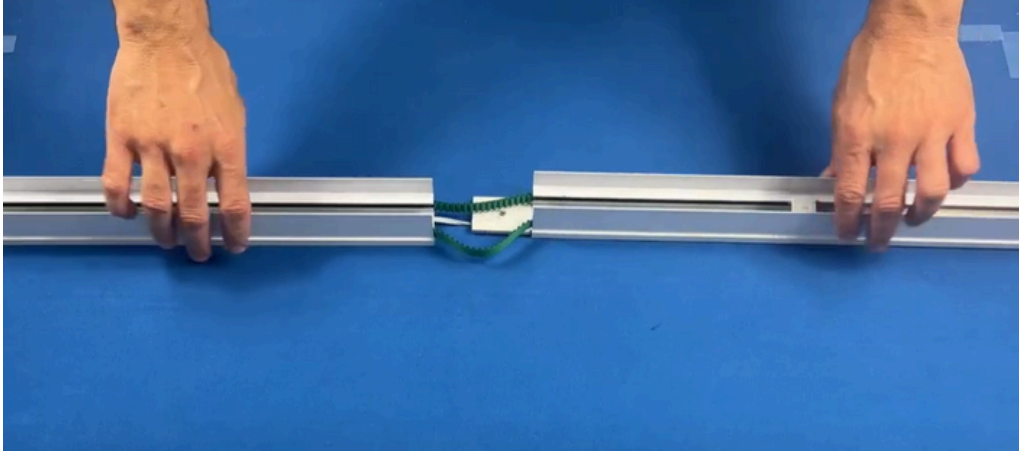

[Scan for assembly instructions](#)
[or click here](#)

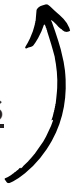

Side channels with Joins

If your side channels have joins, connect the side channels first before proceeding with the installation.

Ensure that there is no gap between the two joined parts.

Refer to the video below.

Important

We are unable to ship joined side channels with the belt loop fully assembled. The accompanying video will guide you on how to connect the belt ends correctly for optimal functionality of the blind.

Please pay special attention to the following images, which demonstrate the correct positioning of the belt connectors when assembling the joined side channels.

Joining The Side Channels

If your blind is over 2.9m long the side channels will come in 2 pieces (for ease of transit).

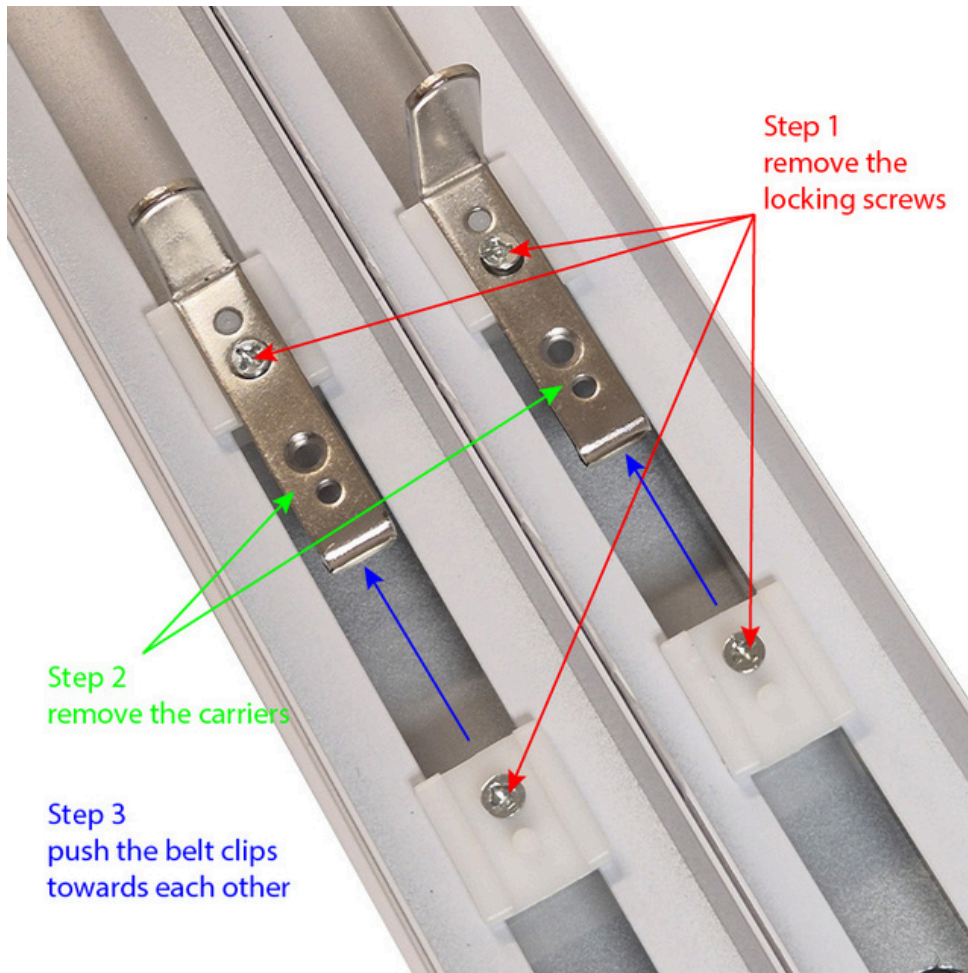

Side Channel and Motor Rail Matching

At this stage, it is crucial to check that you will be fitting the side channels on the correct side of the motor rail assembly. Ensuring that the motor rail assembly and side channels are properly matched is an important step to prevent potential problems later in the installation process. In the picture, you can see the number “1” on the motor rail. Inspect the side channels and look for the same number “1” sticker. Pairing the numbers together will ensure that you put the side channels on in the correct way.

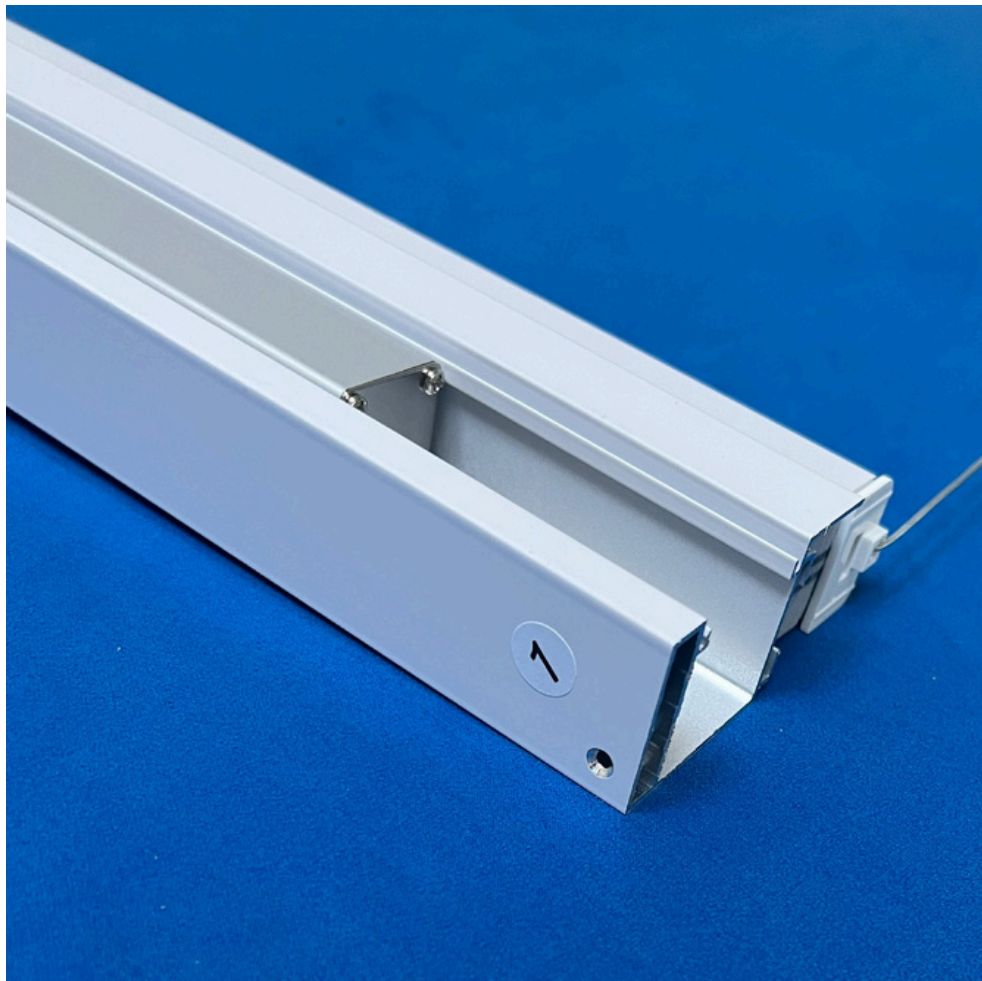

Test The Blind On The Floor

Before you install the blind in the sky it is recommended for you to test it on the floor to make sure it is working as you would like with the remote. The blind should be one touch to open and one touch to shut. Please drop us an email if it is not.

it is very likely that you will have to adjust the floating rail as the blind may be a bit wonky. Scan for instructions below for video on how to straighten the blind. This is easier done before fitting.



[Scan the code or click here](#)

**Test the blind on the floor before
you fit it into your recess.**

BEFORE INSTALLING

INCREASE THE TENSION ON THE SPRING IN THE HEAD OF THE BLIND

Add Tension to the Support Cords

During production, the blind is tested before it's packed and sent out.

We are unable to leave the full tension on the support cords since it would make it impossible for you to install. Therefore, it's necessary for you to add tension to the blind during the installation.

It's recommended that you add tension to the blind when it is in the open position.

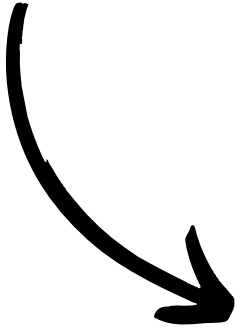

Scan code below or click here for video



Test the blind on the floor before you fit it into your recess.

Install the Blind into the Recess

Now that you've assembled the blind and tested it, you can offer it into the recess and secure it.

Determine whether the motor rail cover strips need to be facing up or down. You will need to know how the blind was ordered for this.

Your blind will either have 4 or 6 pre-drilled holes in the side channels. These are the only fixings you will need to make (unless you are making a double or multi-blind installation; in that case, refer to the relevant section on this page).

You should side-fix the blind through those holes.

The fixing does not have to be overly tight, but it must be firm enough to hold the installation in place.

The most important aspect is to ensure the blind is level before fixing—not just for the blind's operation, but also for the aesthetic appearance of the installation.

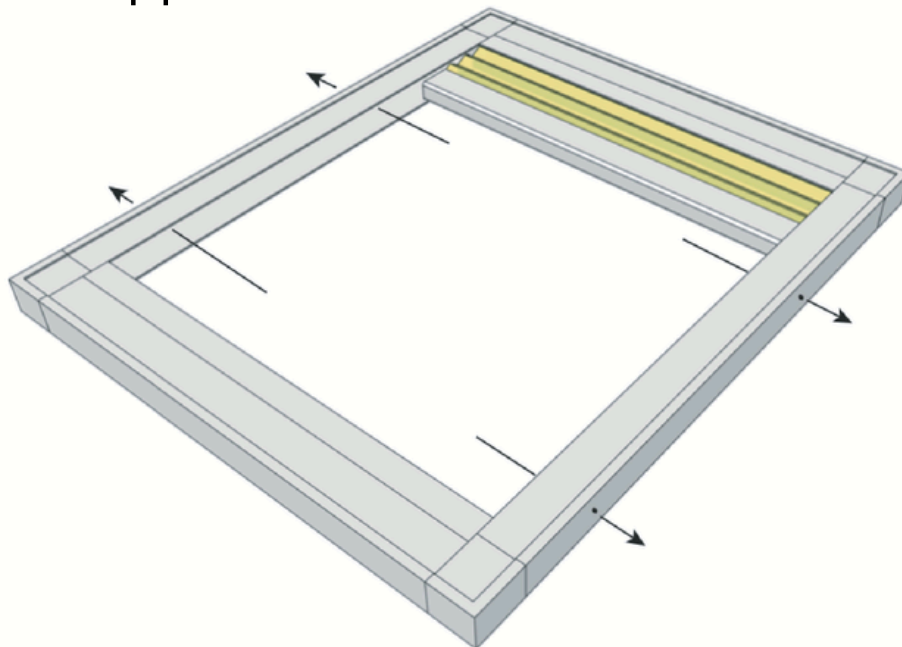

After you've fitted the blind into position, you may want to fill any gaps around the frame with caulk or silicone.

If you didn't order pre-drilled holes or need to make additional holes, you will need to do this yourself.

Drilling Holes:

Make a 10mm hole on the inner channel.

Make a 4mm hole on the outer channel.

Debris Management:

Ideally, use a vacuum cleaner while drilling to suck away the aluminum shavings. This will help prevent any particles from entering the gearbox later on.

Keep in mind that debris in the gearbox can cause the blind to jam.

Setting Side Channels Correctly

Let the Side Channels Relax: Do not screw them tight to the wall until you have checked whether the recess is straight and the walls are parallel.

Checking Alignment: Ensure that the side channels are parallel to each other. If necessary, pack behind the side channels to make them parallel.

Avoiding Fabric Issues: If you do not set the side channels correctly, the fabric may fall out of the track if wind or a vacuum passes through the room. This is because misaligned side channels can cause the fabric to shift or become dislodged.

Hassle-Free Installation: Pre-Drilled Holes for Convenient Mounting

Positioning Your Blind: Hold the blind in the desired place in the recess.

Marking Drill Points: While holding the blind steady, use a pencil to mark the wall through the pre-drilled holes in the frame. This will indicate the locations for drilling.

Drilling: Remove the blind and drill at the marked spots on your wall. Insert the appropriate rawlplugs into these holes.

Securing the Blind: Align the blind with the drilled holes and fix it securely in place.

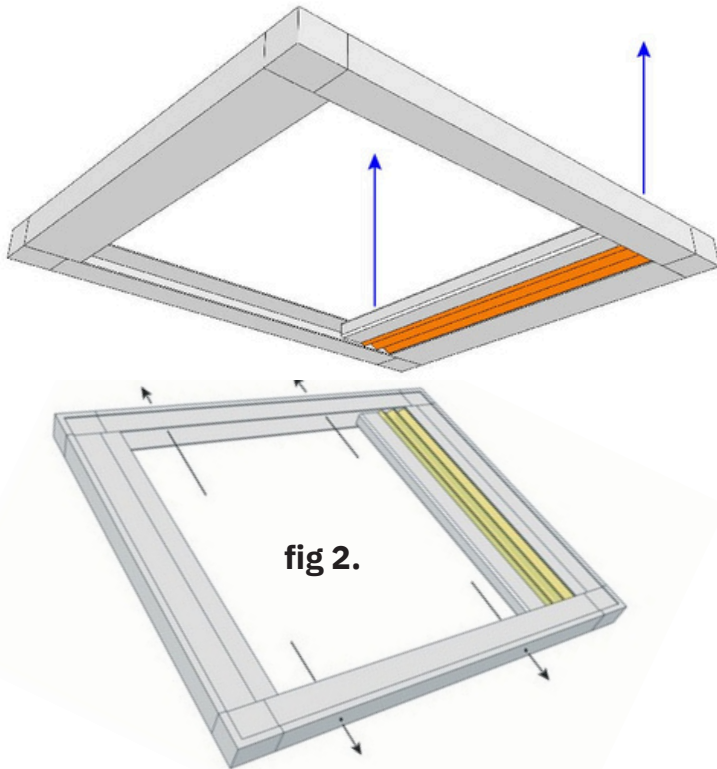

When you install the blind we suggest that you fit the blind with the cover strips facing towards the sky for a streamlined look

Your blind will either have 4 or 6 pre-drilled holes in the side channels. These holes are used to side fix the blind into your recess. See **fig 2.**

The fixing does not have to be that tight, but it must be firm since it will hold the installation in place. After you've fitted blind into position, you may want to fill any gaps around the frame with caulk or silicone. Depending on which power option you've chosen you'll need to either connect the blind to 240v, or fit the solar panel and connect it to the blind.

If fitting a solar panel, simply position it somewhere where it will catch the light. Once the battery is fully charged, you can expect power to last up to four months. The solar panel simply needs to trickle charge the battery over time.

Tips for installing side rails joined with a jointer

When installing a blind with a jointer. Take care to ensure that the side rail holes are lined up horizontally with each other to the mm, otherwise the blind will jump across the joint.

Tips for 'one-man' installation

It's totally possible to fit Honeycomb Openview Electric blind on your own. It is lightweight, and needs only a few fixings. Therefore, you just need to find a way to hold the blind up whilst you secure the it in place.

A simple hack is to mark your 'level line' in the recess, and then hammer some thin nails into the plasterboard along this line at one end of the recess. You will then simply offer the blind up into the recess and sit it on top of the nails, whilst you make some preliminary fixings into the side channels at the other end of the blind.

Electrics

Battery Solar Powered Option

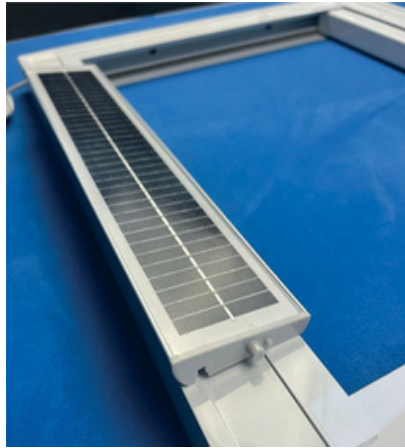

charging port



Foot Of Blind
(where motor is situated)

The battery is hidden in the **head** of the blind. It comes pre charged. It is trickle charged by a solar panel which you sit on the top of the blind. Every now and then you should attach the blind to the charger provided to give the blind a charge. The charging port is discrete and on the underside of the blind. There is another charging port above the blind for the solar panel. The solar panel cable is approx 2.5mts long, so you could locate the solar panel in almost any position, however, it's quite wise to locate it in a position where it will collect the most light.

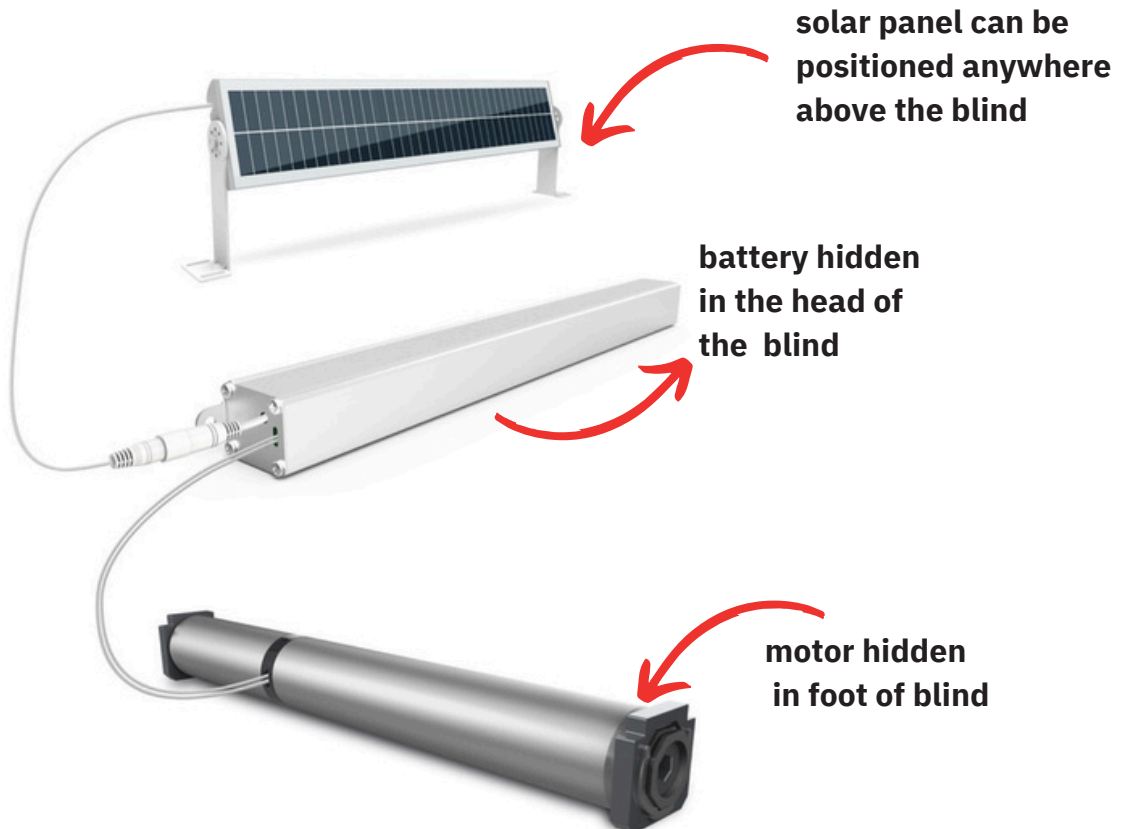

Our blinds come with the NOVO motor as standard and Somfy motor if requested. These instructions are geared towards the novo motor but the Somfy motor works on the same principles and should be similar to set up

Electrics

Battery Solar Powered Option

If your blind is battery-powered, you will need to make a few simple connections during installation.

Please note that the battery also functions as a remote control receiver and motor controller.

The battery contains relays that produce a clicking sound during operation. This is completely normal.

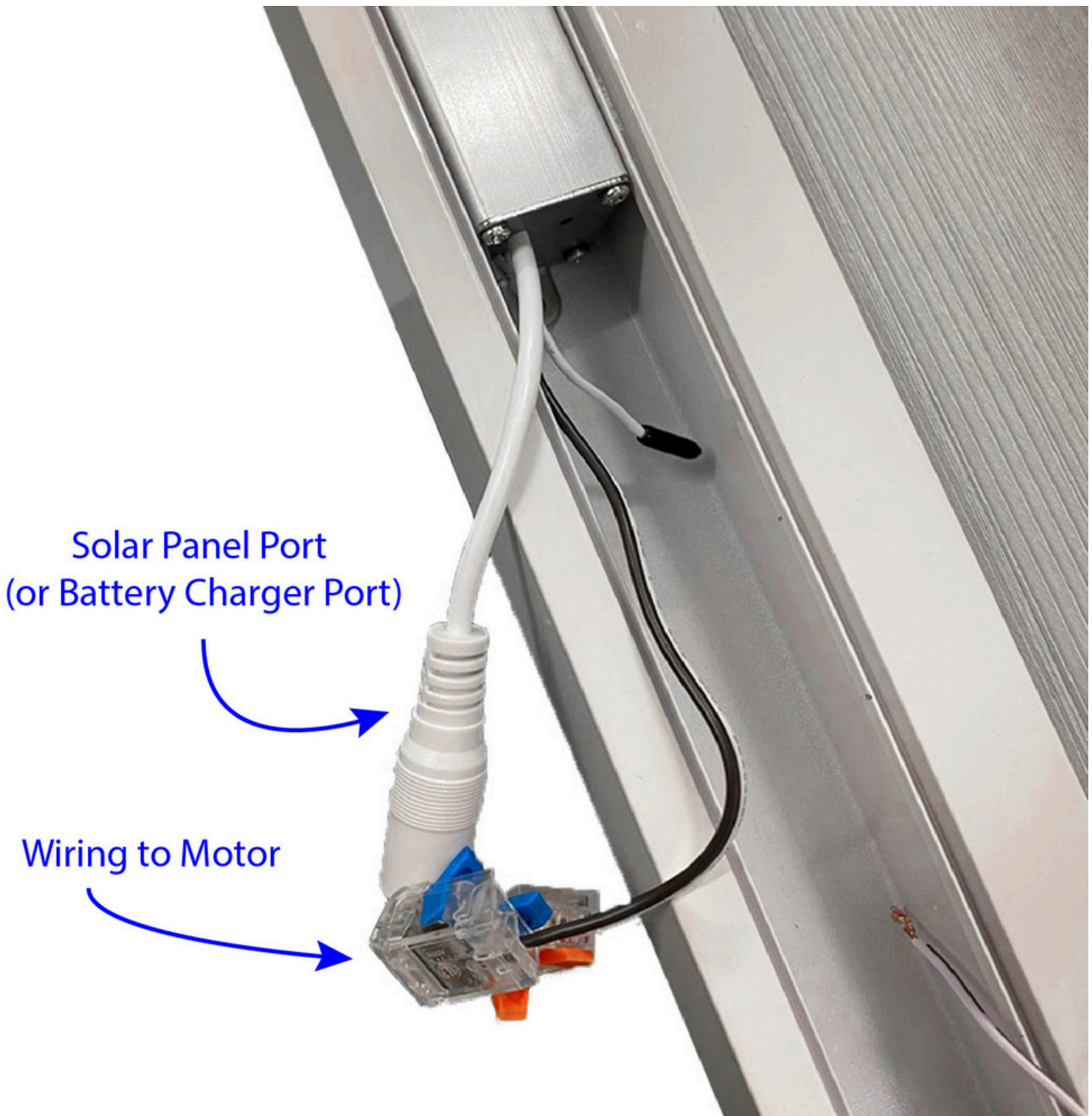

Electrics

Battery Solar Powered Option

White Cable: This cable has a connector port that connects to the solar panel. If the blind does not have a solar panel, this port will connect to the battery charger.

Twin Black/White Cable: This is the output power cable that connects to the motor. Each wire has an attached connector.

Short White Cable: This cable is short, white, and has a black-covered tip. It serves as the receiver aerial and should not be interfered with.

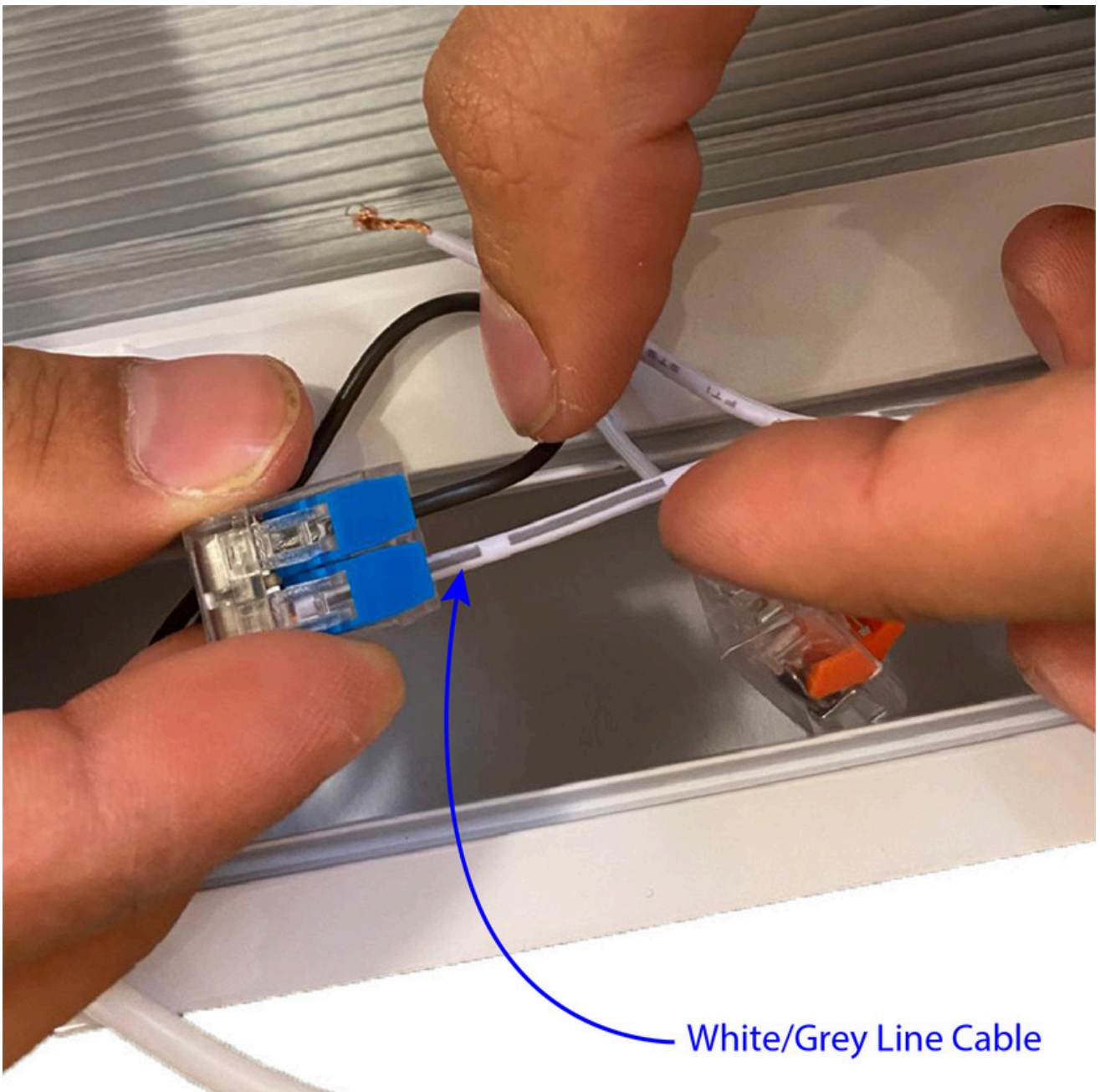

White/Grey Line Cable

Electrics

Battery Solar Powered Option

Carefully examine the white cable that comes from the motor.

One of the cables in this pair will have a grey stripe on it (see photo). Important: The black cable from the battery must be connected to the white cable with the grey stripe. The pure white cable from the motor can be connected to the solid white cable of the battery.

To connect the cables, lift the lever of the terminal to open it.

After inserting the cable into the terminal, close the lever and ensure that each cable is securely locked in place.

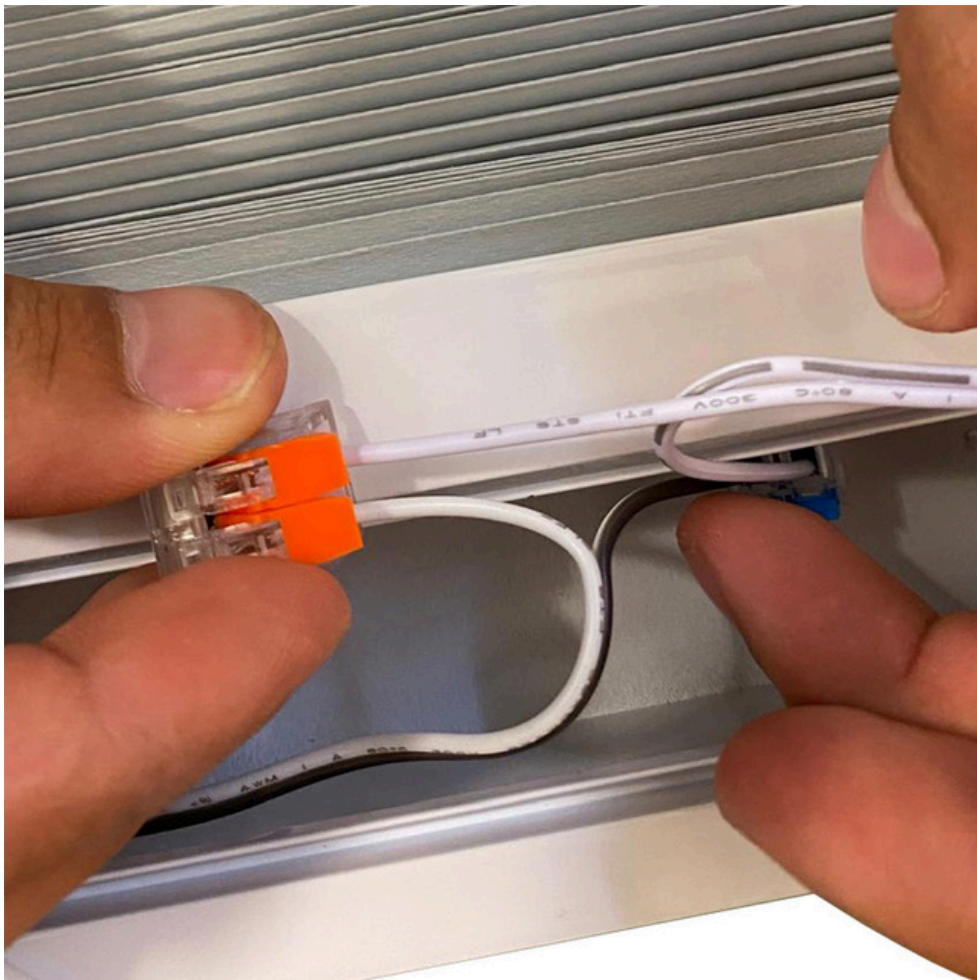

The connections should look like this.



Electrics

Battery Solar Powered Option

Connecting the Solar Panel (if applicable)

If your blind comes with a solar panel, simply position it somewhere where it will catch the light. Once the battery is fully charged, you can expect power to last up to four months. The solar panel simply needs to trickle charge the battery over time.

The cable is approx 2.5mts long, so you could locate the solar panel in almost any position, however, it's quite wise to locate it in a position where it will collect the most light. Whilst brackets are available for solar panels, often installers find it simpler and less intrusive to sit the solar panel on top of the blind motor rail. If you are concerned about vibration moving the solar panel over time, then dab a blob of silicone (or double sided tape) under the solar panel to hold it in position.

Alternatively the panel can be fitted elsewhere where it will get the most exposure to light such as on a nearby wall or surface, where it will receive the most direct sunlight. For this, you will need a pair of brackets (optional extra).

Once the battery is fully charged, you can expect power to last up to four months. The solar panel simply needs to trickle charge the battery over time.

When installing a solar panel, ensure that it is not placed on any window glass with a light transmission of less than 65% (including Low E glass and window tinting), or obstructed by a secondary window pane or bug screen. Additionally, always keep the photovoltaic cells unobstructed and do not place any objects in front of them.

Electrics

Mains Powered Option



Transformer



Head Of Blind



The mains transformer is hidden away in the head box at the fabric end of the blind. After the initial assembly, leave the cover off, or simple remove it if it's already fitted.

To remove it, we suggest a flat blunt tool Cable Exit Position such as a filler knife rather than a screwdriver. Be sure not to bend the cover when removing it. It just needs some agitation rather than brute force to remove it. Use a flat head screwdriver to push the yellow terminal springs in the direction shown. This will open the cable hole giving you enough space to push your power cable into the port. Release the terminal springs to lock the cable in place. Fit the cover strip profile into place when done.

Your AC 240v cable goes into the INPUT side of the transformer.

The + terminal is LIVE The - terminal is NEUTRAL

A 0.75mm twin-core flex cable is more than adequate for the installation. The transformer is 'double insulated', it doesn't have an earth connection.

[Scan for assembly instructions or click here](#)

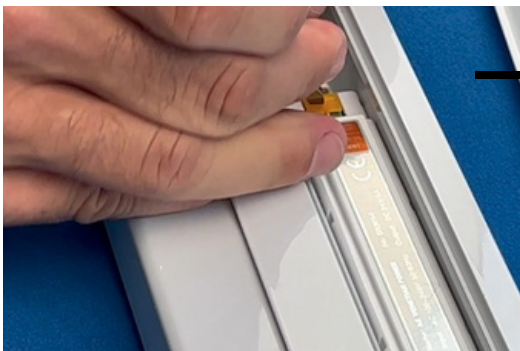
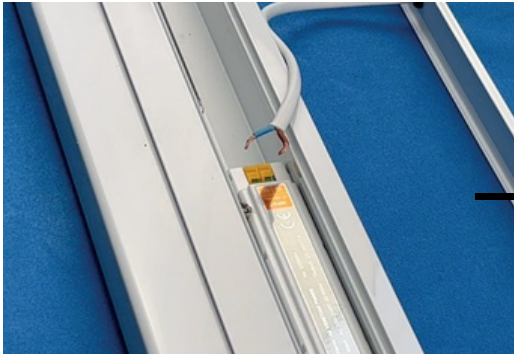

Our blinds come with the NOVO motor as standard and Somfy motor if requested. These instructions are geared towards the novo motor but the Somfy motor works on the same principles and should be similar to set up

Handsets

Remote Control

Connect up to 6 blinds with this handset



Switch

This single channel switch is a remote transmitter and doesn't need cables. Simply screw it to the wall. Only compatible with the mains powered motor.



Our blinds come with the NOVO motor as standard and Somfy motor if requested. These instructions are geared towards the novo motor but the Somfy motor works on the same principles and should be similar to set up

TROUBLE SHOOTING

Problem: The blind isn't working with the remote

use the remote to scroll to channel 6, and then go one channel past channel 6. This is the group channel and all the lights on the remote should light up when you are on this channel.

Does the blind now work?

If not please check the power to the blind. If it is a battery powered blind please make sure that the power is properly attached to the blind. If it is a mains powered blind please make sure the powered is connected properly to the blind

If this does not work please email us with a description of the problem to team@skylight-blinds-direct.co.uk

Blind is pulling over wonky- did you fit the L brackets?

Did you fit the L brackets down the side channels? (you will find these in the packaging if your blind has a join down the side channels). The L brackets are already installed if your side rails are not in 2 x parts.

Rewatch this video



[Scan the code or click here to watch the video](#)

Blind is pulling over wonky- adjust rods



[Scan the code or click here to watch the video](#)

Problem: Blind doesn't shut properly

If the blind does not completely close or stops short of the closing position, then the motor limits should be reset.

Sometimes is possible that the motor limits are no longer in sync if you have built the blind and then disassembled it.

RESET THE MOTOR LIMITS

1. Open the blind fully*
2. Physically hold the float rail securely so as to stop it from moving (you are about to hit the close button!).
3. Press the button on the transmitter that would normally close the blind.
4. You will feel a slight 'jog' on the float rail. The motor limits have been erased.
5. Now press the close button again and let the blind run to the end. When the motor detects an obstruction, it will stop and set that position as the final limit
6. See this video <https://www.youtube.com/shorts/KxyMZr5LGdY>

*If your blind is stuck halfway and you need to motor reset, please do the following:-

- Get the blind to the almost CLOSED POSITION (leaving enough room for your hand to get in)
- Very gently start pushing manually the blind back with your hands so the blind is totally open
- Then follow the motor reset video

For any other problems please email team@skylight-blinds-direct.co.uk